

# HV255.45i

## INDUCTION SYSTEM SISTEMA DI INDUZIONE

### FURNACE / FORNO

- Compact system
  - Saves space
  - Integrated in the process
  - Inducton coils
  - Adjustable billet (during production)
  - Fast and stable heating
- Sistema compatto
  - Risparmio di Spazio
  - Integrato nel processo
  - Bobine di induzione
  - Tassello (billetta) regolabile (durante il processo)
  - Riscaldamento veloce e stabile

### BAR FEEDING / ALLIMENTAZIONE DELLA BARRA

- Automatic bar feeding
- Load up to 2 tn
- Automatic recovery of heated bar
- Minimal waste of time and raw material

- Alimentazione automatica della barra
- Caricare fino a 2 tn
- Recupero automatico della barra riscaldata
- Minimo spreco di tempo e materia prima

### HYDRAULIC PRESS / PRESSA IDRAULICA

- No flash
- Senza bave

### BAR STORAGE / MAGAZZINO BARRE

- Bar capacity: up to 2 tn
- Capacità di carico barre fino a 2 tn

### PUNCH MOVEMENTS CONTROL / CONTROLLO DEL MOVIMENTO DELLE SPINE

- Adjustable features (during production)
  - Speed (in&out)
  - Time (in&out)
  - Main pressure
- Caratteristiche modificabili (durante la produzione)
  - Velocità (di ingresso ed uscita)
  - Tempo (ingresso ed uscita)
  - Pressione principale

### CUTTING SYSTEM / SISTEMA DI TAGLIO

- No shavings
  - Compact cutting
  - Adjustable billet cutting (during production)
- Senza trucioli
  - Sistema integrato
  - Possibilità di regolare l'altezza della billetta/tassello (durante la produzione)

### TOUCH SCREEN / PANNELLO TOUCH

- Functional configuration
- Configurazione funzionale



## SPECIFICHE TECNICHE

### DESCRIPTION AND BENEFITS DESCRIZIONE E VANTAGGI

Fully automated and compact process: furnace + cutting system (shavings-free) + hydraulic press with no flash, 5 independent punches (4 horizontal + 1 vertical)

### BAR RANGE / BARRE

From Ø 12 mm to Ø 45 mm and up to 4 m (length).

### ELECTRICAL SYSTEM SISTEMA ELETTRICO

Voltage	3 ~ 400 V 50 Hz    3 ~ 460 V 60 Hz
Max. power supply	130 kW
Hardware	18.5" touch-screen, EMBEDDED industrial PC, PLC control

### PRODUCTION CAPACITY CAPACITÀ PRODUTTIVA

Production	Up to 4.000 items/hour
Bar diameter	From 12 to 45 mm
Bar length capacity	Up to 4.000 mm
Minimum weight	15 g/piece
Maximum weight	2.800 g/piece
Bar length	200 mm

### HYDRAULIC SYSTEM SISTEMA IDRAULICO

Main motor power	110 kW
Main motor power	1.000 l
RAM	Force: 180 Tn (250 bar) Stroke: 510 mm
Punch	Force: 129 Tn (280 bar) Stroke: 120 mm
Graphite oil tank capacity	50 l

### PARTS THAT CAN BE PRODUCED PEZZI CHE POSSONO ESSERE PRODOTTI

Ball valves, tees, elbows, taps...  
From 1 to 4 pieces/cycle

### MATERIALS / MATERIALI

Brass, lead-free brass, copper, red brass, and aluminum.

### FURNACE CAPACITY CAPACITÀ DEL FORNO

Energy source	Electrical
Max. installed capacity	100+100+100 kw
Consumption	From 30 to 300 kw
Max. capacity	700 kg/h at 700°C

### WEIGHT AND DIMENSIONS PESI E DIMENSIONI

Empty weight	25.500 kg
Total height	4.105 mm
Total height with fume filter	4.250 mm
Total length	10.010 mm
Total width	3.440 mm
Total width with bar loader	4.185 mm

NOTE: specifications according to EC standards



# HV255.45

## HV255.45i

### PRODUCTION FLEXIBILITY

- Quick production format change
- Easy forging die change

### FLESSIBILITÀ DI PRODUZIONE

- *Cambio rapido del formato di produzione*
- *Cambio facile della matrice di stampa*



- > WATER FITTINGS
- > GAS FITTINGS
- > HYDRAULIC FITTINGS
- > PNEUMATIC FITTINGS
- > AUTOMATIC FITTINGS
- > BALL / GATE VALVES

- > RACCORDI PER ACQUA
- > RACCORDI PER GAS
- > RACCORDI IDRAULICI
- > RACCORDI PNEUMATICI
- > RACCORDI PER IL SETTORE AUTOMOBILISTICO
- > VALVOLE A SFERA / A SARACINESCA

HV255.45

HV255.45i

1 **BRASS**  
**OTTONE**

2 **ALUMINUM**  
**ALLUMINIO**

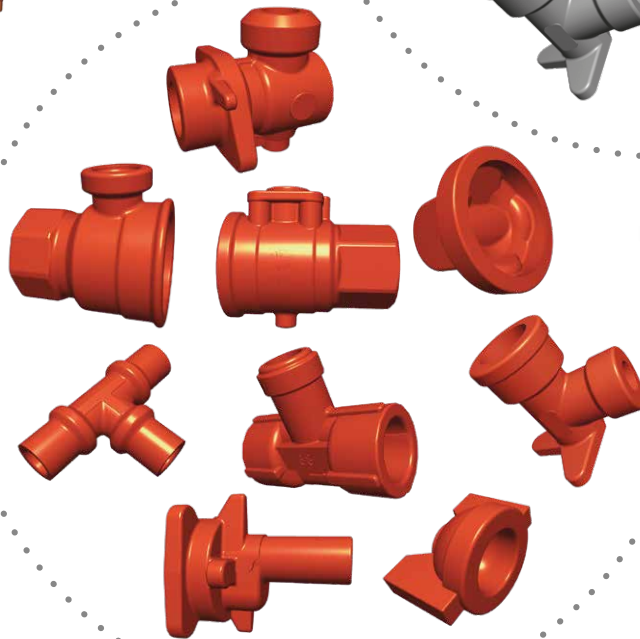
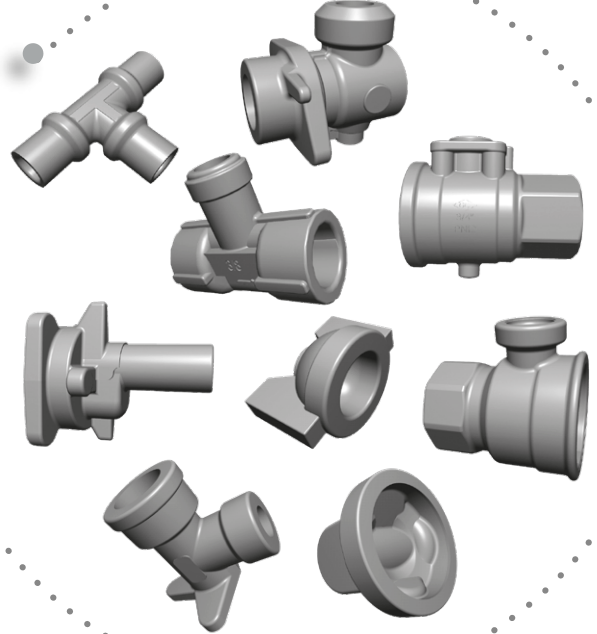
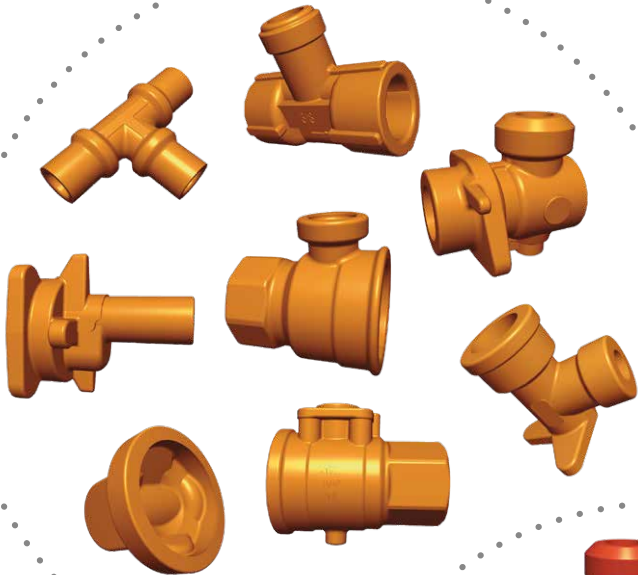

3 **COPPER**  
**RAME**



**BAR DIAMETER**

MINIMUM 12 mm

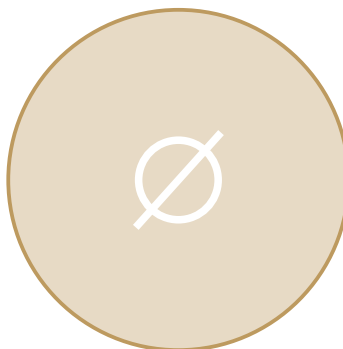

MAXIMUM 45 mm

